

**MDK Magnetic Nondestructive Testing
Equipment**

Kaisei Hi-tec Co.,Ltd

Internal defects of metallic materials can be identified by means of nondestructive MDK methods.

MDK sensor(Magnetic Detector of KAISEI)

MDK sensor is a specially designed, patented electromagnetic induction sensor. In simple terms, an AC magnetic field is developed by a sensor coil and is positioned to penetrate a piece of test material. This magnetic field then naturally returns to the sensor. In case there exist defects such as cracks, hardening, metal fatigue and plating detachment either on the inside and or outside of the test material, the returning magnetic field will be effected. This effect is measured by the electromagnetic induction sensor.

MDK sensors measure amplitudes and phases of voltage which occur on the sensor windings when a magnetic line of force is interrupted. By special design, variations of amplitude indicate changes in the conductivity of the test material, and changes of phase indicate changes of magnetic permeability of the material. By measuring such changes, it is possible to interpret these as defects in the test material.

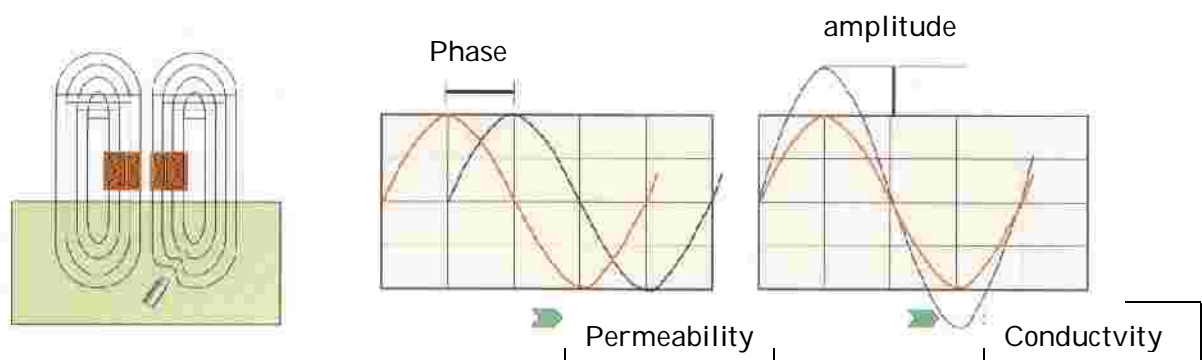

MDK Sensor

Information about the inside of material is obtainable by nondestruction.

Information on comparatively deep parts is also available.

Both information available on "changes of material itself" and "various other types of material".

Quick measurement is completed simply by applying a sensor.

Irrespective of surface form, internal defects can be detected.

Continuous measurements also applicable.

A portable version of the system is available which allows the operator to take it to the test site.

Construction

MDK sensor setup consists of a main body console which has the magnetic sensor probe, AC power source, detector/amplifier and AD converter, controller and computer for data processing.

A portable console is also available, and in combination with a notebook PC, it is possible to carry the entire system onto the job site.

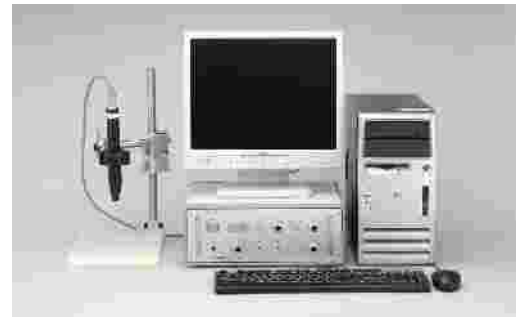

Various sensors available according to purposes

By customizing the sensor to fit the application, it is possible to control transmission distance to a test piece, spatial resolution and also resolution of amount of change detected. Thus, it is possible to customize according to the wide range of industry application..



Damages inside materials.
Contaminations

- flaw • crack
- inclusion • deposit
- contamination
- incomplete welding
- blowhole of casting
- plating detachment

Quality change of materials.

- axial force • metal fatigue
- thickness, fatigue • creep
- depth of hardened layer
- plate thickness
- hardness
- density • kind of metal
- foreign material • corrosion

Crack Inspection on Cast Iron Sleeve

While cast iron sleeve is rotated on a turning table (30rpm), the flange is inspected by a pentype sensor. The below shows that MDK sensor reacts sharply at a certain point of test piece. It is also confirmed by means of color checking that there was a crack at the portion reacted.

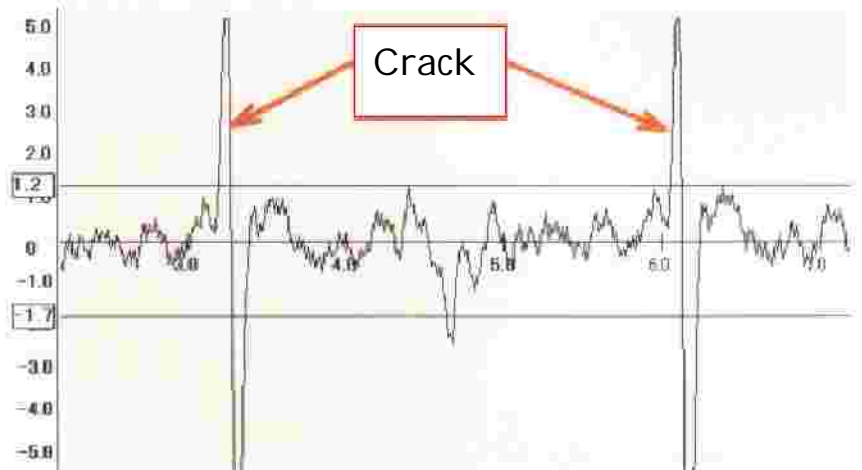

Pinhole Detection of Arc Welding

Measurement has been made on the fillet welded portion where defects of a (crack), b (blowhole), c (crack) and d (slag inclusion) had been made manually beforehand. Each defect appears clearly.

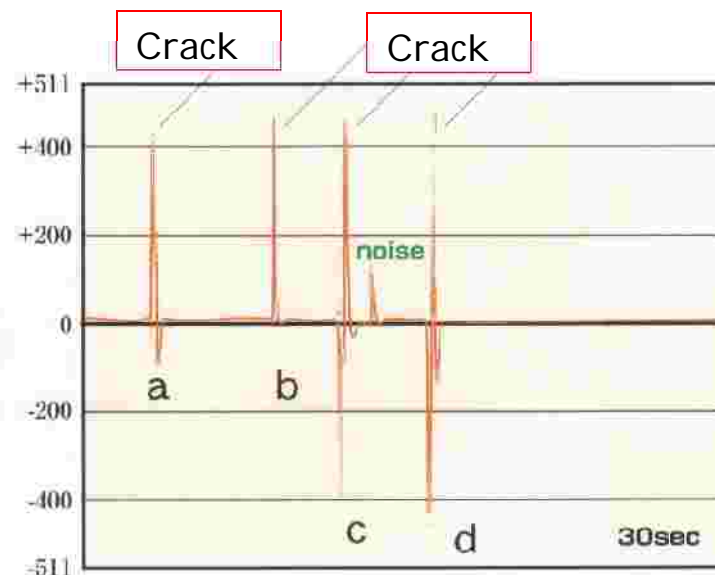

Spot Welding



Measurement has been made on the fillet welding.

Spot Welding Inspection is carried out by applying a pen-type sensor onto the welding nugget. As the nugget is not always in exactly the same shape and sometimes tapered on the surface inspected, the evaluation is made by means of peak values measured through a sensor. As shown in the graph, tensile strength-MDK value has a relationship of almost straight line, and it is possible to obtain tensile strength from MDK value.

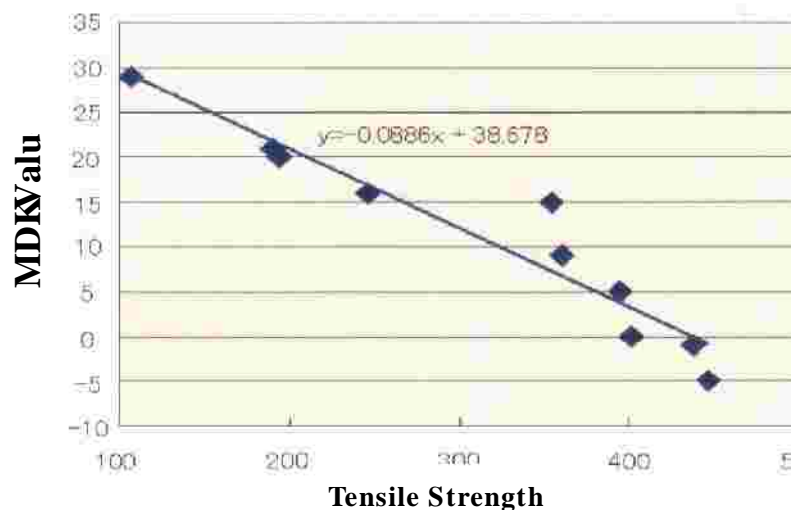

Pinhole Detection of Arc Welding



Designed to inspect pinholes existing inside a welded portion of two iron plates approx.2.4mm in thickness. The test piece had been inspected beforehand by means of x-ray and was confirmed that pinholes of approx.9.0mm in width existed in the bead welding.) As the sensor scanned the top of bead weld, the detected wave form changed significantly (same position as in x-ray inspection).

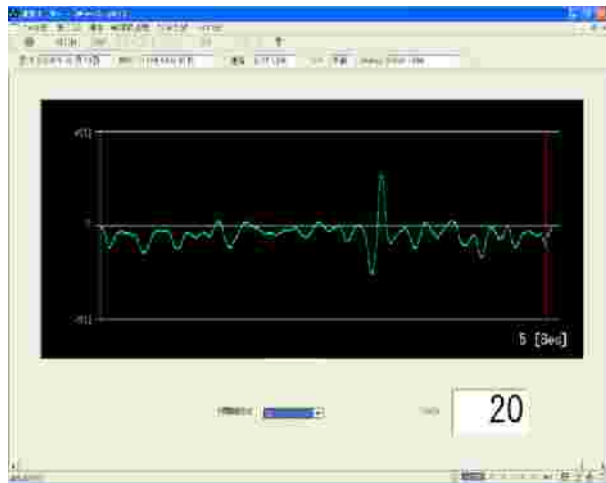

Inner Crack detection
of Stainless
Steel 304

It is possible to detect the inside crack, while a sensor scans the stainless steel pipe (wall thickness of approx.3.5mm) along the direction of circumference.

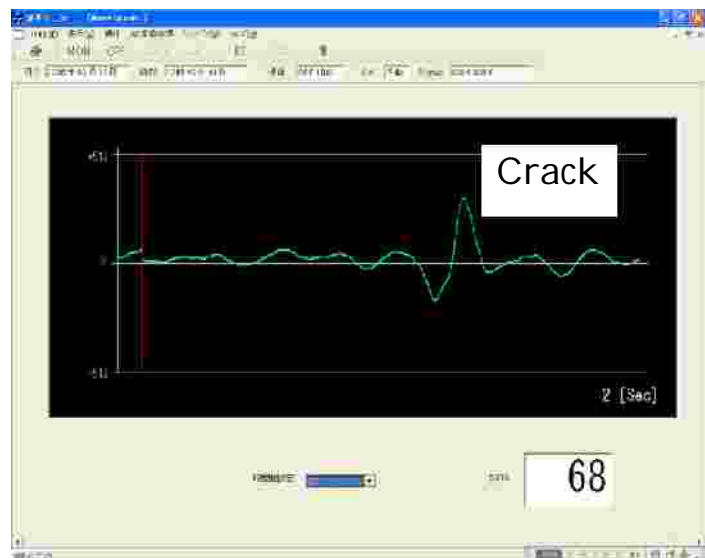

Detection of Foreign Articles

It is possible to measure the change of axial force when tightened by bolts simply by applying a sensor. Volume change of phase was measured by setting bolts of 3kg output voltage of almost 0V

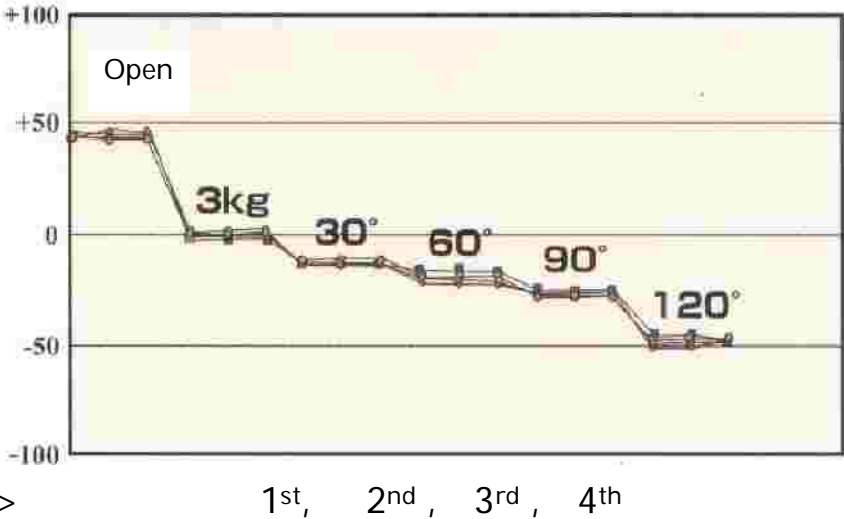

Axial Force Measurement

The data below is the result of scanning the face of iron plate by MDK sensor.

The iron plate of 3.5cm in thickness is beforehand attached with the foreign articles such as a. sludge b. correction pen c. signature pen, d. wire and e. punch hole at a size of 0.5mm on the bottom side, and then joined together with aluminum plate. Each foreign article is detected from 3.5mm thick iron plate with high accuracy.

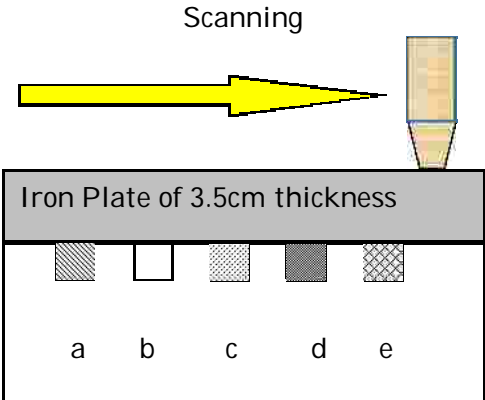

Alminum Plate fusion

- a. sludge
- b. correction pen
- c. signature pen
- d. wire
- e. punch hole

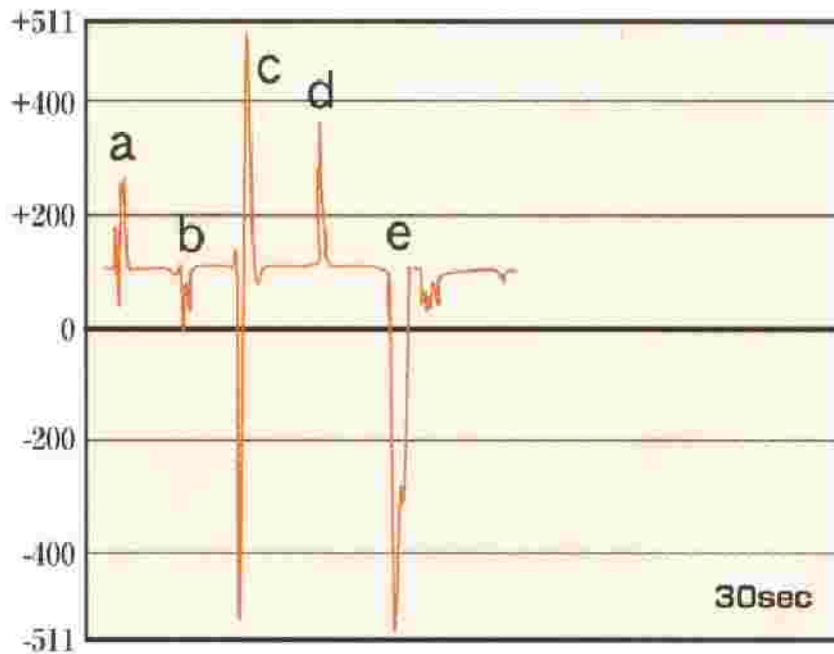

When nondestructive inspection of material is required

Please contact us if you are experiencing difficulty with your existing technique or have the requirement for more simple and speedy inspection.



Design and manufacture of sensor



Quotation

Test and study of measurement condition



2nd meeting

Receipt of test piece



Kick-off meeting

Please contact us

Upon receipt of the contact, we ask for test pieces and carry our MDK sensor to the job site for field testing. After detailed discussion, we make various testing and decide if customer's request could be met or not, and also study inspection accuracy. Based on such result, we can design the probe most suitable for customer's purpose and deliver the equipments with our measurement conditions.

Patents registered in Japan, U.S.A., England, Netherland, Germany, Korea and Taiwan.

Technical specifications to be changed for improvement without prior notice.